

SIDEWALK CAFÉ PERMIT GUIDE



PURPOSE

The purpose of this guide is to provide standards and to simplify the Sidewalk café use in order to enhance the quality and safety of the pedestrian experience, as well as reinforce downtown's sense of place and economic vitality. Compliance with all applicable sections of the ordinance and guide is required at all times. The design requires that a high priority be placed on creating a comfortable and aesthetically pleasing public space for our community, its citizens and visitors. This Guide was produced by the City of Rome Office of Downtown Development and the Downtown Development Authority.

Submit Application to:

**Downtown Development Office
607 Broad Street
PO Box 1433
Rome GA 30162**

Ordinance No. 2007-6-2

**Adopted June 18, 2007
Amended June 6, 2011
Amended May 26, 2015**

CITY OF ROME

CHAPTER 11 Licenses, Permits and Business Regulations

ARTICLE 11 Miscellaneous Licensing and Regulation

SECTION 11-60 Sidewalk Cafes.

(A) DEFINITION

The following words, terms and phrases, when used in this section, shall have the meanings ascribed to them in this subsection, except where the context clearly indicates a different meaning: *Sidewalk café* means an area of food service located outside, but connected with, a part of, and adjacent, an indoor restaurant or café located in the city.

(B) APPLICATION FOR PERMIT

Notwithstanding the provisions of sections 20-1 through 20-4, a licensed restaurant may apply to the City's Office of Downtown Development for a permit to operate a sidewalk café. Such application shall contain at least the following information: 1. The name and address of the licensee; 2. The proposed location and 3. a description of the proposed use or occupancy of the public right of way; and 4. Such other information as may be required by the Office of Downtown Development.

(C) CONDITION FOR PERMIT ISSUANCE

Upon review and approval of the Office of Downtown Development, the City Clerk's Office shall issue a permit containing restrictions, terms, and conditions to ensure the proper use for public property and to protect the health, safety and welfare of the city, including the following:

(1) The area permitted for Sidewalk cafes shall be so located and maintained that only the following portion of the sidewalk shall be used:

a. Within the CBC district no more than an eight (8) foot portion of the sidewalk measured from the face of the restaurant perpendicularly toward the curb.

b. Within the eight (8) feet from the outside wall of the restaurant and perpendicular to the curb a minimum of four (4) feet shall be provided at all times from continuous unobstructed pedestrian traffic on the sidewalk between the sidewalk café area and the curb or nearest obstacle.

c. Permanent plantings, City owned waste receptacles, streetlight poles and other permanent fixtures along the sidewalk must be considered when determining the boundaries set forth in a permit.

d. The Office of Downtown Development shall serve as the review agency for site plans, specifications, fixtures, materials and annual renewals.

(2) Any special construction proposed to encroach upon or occupy any of the public right-of-way shall be permitted only by prior approval of such plans by the chief building official.

(3) The permit holder of any Sidewalk café shall at all times ensure that:

a. No encroachment on public rights-of-right, other than as stated in this section, shall be allowed to exist.

b. All restrictions, terms and conditions of any permit granted for sidewalk cafes shall be met.

c. All general provisions and clean community regulations of the refuse collection and disposal provisions of Chapter 19 are complied with.

(4) The issuance of a Sidewalk café permit shall not be construed or interpreted to convey any property rights or any other rights not expressly set forth in such permit.

(5) Permits are renewed within the first quarter of each calendar year.

(D) REGULATIONS

Except as otherwise provided, a Sidewalk cafe operating in Rome shall comply with the following:

1. Limitations on area

The area in which a sidewalk cafe is operated shall abut the outside front wall of the restaurant of which it is an extension and shall not extend in either direction beyond the outside front wall of the restaurant.

2. Divider required

Restaurants where alcohol is served the area permitted for a sidewalk cafe shall be separated from the remaining sidewalk area by a system of connected posts and railings that serves to contain crowds and maintain the boundaries of the cafe. The system shall be designed and constructed such that it resists movement and can be disassembled and removed, if necessary. The design must be included in the application and must be approved prior to issuance of a permit. Such divider railing shall not be more than three (3) feet (thirty six 36) inches with post no more than three feet six inches (42 inches) in height. All tables and chairs shall be located totally within the

limits of the divider. It shall be the responsibility of the permit holder to maintain the divider in its exact approved location at all times.

3. *Sanitation*

It shall be the responsibility and duty of the restaurant to which the Sidewalk cafe permit is issued to maintain the area covered by the permit in a clean, neat, and orderly manner at all times. The area shall be cleared of all debris at all times. Permit holder shall sweep the sidewalk and collect debris. All tables and chairs are to be kept clean, sanitary, safe and in structurally sound condition at all times.

4. *Removal of furnishings and suspension of operation*

All tables, chairs, and dividers of a Sidewalk cafe shall be removed from the public sidewalk area from time to time and outside operations suspended as required by the City of Rome for sidewalk cleaning or for such other purposes as the City may determine, in its sole discretion for such purposes as, but not limited to:

- Any permitted special event;
- Any street, sidewalk or utility construction;
- Any emergency situations; or
- The protection of the health, safety and welfare of the public.

5. *Alcoholic Beverages/Open Containers*

Sidewalk cafe permit holder shall be exempt from the restrictions on open containers if such establishment is otherwise licensed to sell alcoholic beverages under the applicable laws and ordinances. All applicable provisions of Chapter 3 (Alcoholic Beverages) of the code of the City of Rome and regarding the sale, service, possession, and Title 3 (Alcoholic Beverages) of the official Code of Georgia shall be enforced consumption of alcoholic beverages. The permit holder shall post approved signs designating the limits of the open container area.

6. *Furnishings*

Furnishings shall not be secured to lamp posts, streetlights, trees or any other public street fixtures. Furnishings may not be stacked or stored outside on the public right-of-way at any time.

- Fencing.** A system of connected posts and railings, firmly secured, but temporary moveable shall serve to maintain the boundaries of the Sidewalk cafe and allow visibility to street patrons. A fence in any approved location will in no instance be a visual barrier to vehicular traffic or impede driver visibility. Fence materials are to be discreet in color, design, materials and finishes and relatively transparent. Flower boxes or planters may be used to define the corner boundaries of the area.

- Menu boards and signs.** Menu boards both portable and on walls, shall be subject to sign permit approval and shall comply with City Code.

- Trash Receptacles.** The number, type and location of receptacles shall be subject to approval.

- Umbrellas.** Each table may be equipped with an umbrella that, when open, shall extend to at least the same diameter as the table it serves and shall be anchored with a weighted base. Any umbrella protruding into public space shall be positioned at a minimum height of seven feet. An umbrella may not display the name or logo of the restaurant operating the sidewalk cafe and/or advertise a product. Each umbrella shall be maintained in good, clean, and operable condition.

- Tables and Chairs.** Materials. Tables and chairs shall match and be made of safe, sturdy and durable material, such as wood, steel, or wrought iron. All furniture shall be commercial grade and manufactured for outdoor commercial use. Small round or square tables shall seat no more than four people. Use of larger tables may be granted provided that all clearance requirements are met. Round tables shall be no larger than three (3) feet diameter. Square tables shall be no larger than three (3) feet wide and rectangular tables no more than three (3) x four (4) feet. Tables shall be no more than thirty inches (30") in height.

7. *Landscaping*

The combined height of the planters and live plants shall not exceed four (4) feet from sidewalk grade and no wider than two (2) feet at the base. The planting areas shall be planted with seasonal blooming or ornamental evergreen live plants year round. The permit holder shall maintain flower boxes and planting areas. The flower boxes, planters and trash receptacles shall be portable and made of safe, durable and attractive materials such as wood, steel or colored concrete.

8. *Hours of Operation*

A business with a sidewalk café permit may be open for breakfast, lunch and/or dinner and any Combination thereof, consistent with the businesses normal hours of operation.

9. *Smoking*

Those businesses which are prohibited by State or local law from allowing smoking within the interior of their establishments may not allow smoking within the area permitted for a sidewalk café.

10. *Guidelines*

The City shall adopt standards and guidelines for consideration of applications without amendment to this article.

(E) LIABILITY AND INSURANCE

The City of Rome shall require permit holders to indemnify and hold harmless the City and its officers and employees from claims and liability arising out of the permit holder's use of a sidewalk obtain insurance covering the use of a sidewalk café and to name the City of Rome as an additional insured with respect to such insurance. The City of Rome shall prepare guidelines with respect to any indemnification and insurance requirements of permit holders.

(F) REVOCATION OR SUSPENSION OF PERMIT

The approval of a Sidewalk cafe permit is conditional at all times. A sidewalk cafe permit may be revoked or suspended by the City's Code Enforcement Officer, upon approval of the City Clerk's Office, if it is found that:

- (1) any necessary business or health permit has been suspended, revoked, or cancelled.
- (2) The permit holder is not in compliance with any of the City's regulations with respect to Sidewalk cafes.
- (3) The permit holder has failed to correct violations of this chapter or any other ordinance within forty-eight (48) hours of receipt of the notice of same delivered in writing to the permit holder.

- (4) The permit holder has a history of violations of this chapter of three (3) or more within a two (2) year period, or immediately upon any violation depending upon severity of the violation.
- (5) Permits may be suspended for a period up to twelve (12) months depending upon history and severity of violations.

(G) FINES FOR VIOLATORS.

In addition to the possible revocation or suspension of a permit, the following minimum fines shall be imposed for violations of this chapter: First citation: \$100.00 fine. Second citation (within one-year period): \$250.00 fine. Third and subsequent citations (within one-year period): \$500.00 fine.

(H) AMERICANS WITH DISABILITIES ACT.

Any person or entity receiving a permit hereunder agrees to fully comply with all requirements of the Americans with Disabilities Act as currently existing or as may be hereafter amended

THE PROCESS

Eligible restaurants that would like to establish a sidewalk café must obtain a sidewalk café permit prior to operation in the public right-of-way. The café operator shall meet all conditions and requirements for a sidewalk café permit at all times.

- Request an application for a Sidewalk Café Permit from the City Clerk's Office, City Hall, 601 Broad Street or from the Office of Downtown Development, 607 Broad Street, Carnegie Building, lower level.
- Submit application and supporting documentation to the Downtown Development Office, 607 Broad Street, Carnegie Building, lower level.
- Applicants are contacted if the documentation is incomplete or additional information is necessary. Only fully completed submissions are reviewed for permitting.
- When the request has met approval, the application is then forwarded to the City Clerk's Office for permitting.
- Upon review and approval by both departments (Downtown Development for design review and City Clerk for permitting) the sidewalk café may be installed.
- Permit must be renewed annually.

DEFINITIONS

SIDEWALK CAFÉ: A sidewalk café means an area of food service located outside, but connected with, a part of, and adjacent to, an indoor restaurant or café located in the City.

SIDEWALK CAFE DISTRICT:

A sidewalk café is allowed within the C-B-C Central Business Commercial District. The CBC district is intended to serve as the central headquarters for economic and administrative activity in the community and pedestrian friendly. The district is designed to have uses that are centrally located and compact so that maximum convenience is afforded the users and occupants of the district.

CBC District
Central Business Commercial

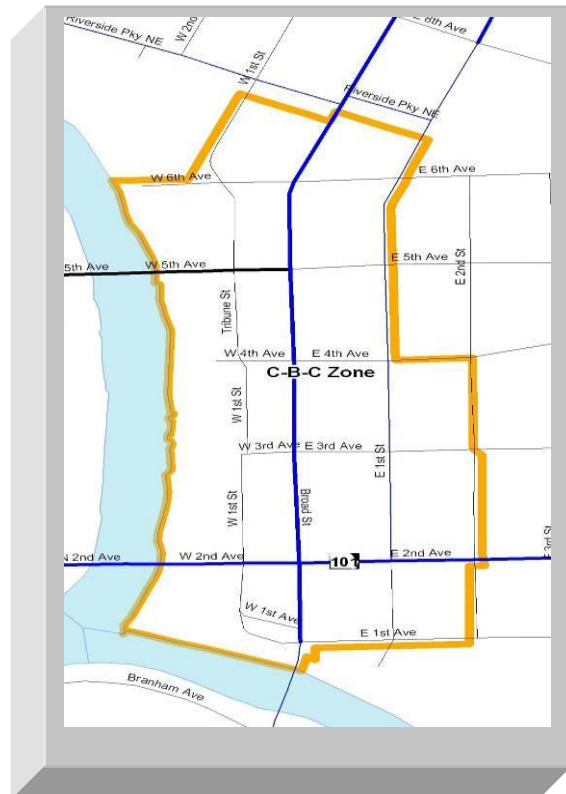

DEFINITIONS

SIDEWALK CAFÉ AREA: The sidewalk café area can be defined as:

- 1) the space delineated by the facade of the building to the adjacent street, perpendicular to the pedestrian zone (public right of way);
- 2) the recessed entries immediately adjacent to the outdoor sidewalk cafés.

ACTIVITY ZONES

Any sidewalk café area may be viewed as containing four Activity Zones which must be respected at all times and include: Adjacent, Café, Pedestrian, and Vehicular.

ADJACENT - This zone applies to buildings with recessed entries that can accommodate café seating with tables. There shall be a minimum of 5 foot clear path from any entrance/exit door. This clearance may overlap with the pedestrian path clearance. A minimum 5 foot clear wide path shall remain open between the café entrance door and the sidewalk/pedestrian zone.

CAFÉ - This zone allows for the temporary installation of sidewalk café improvements (i.e. tables, chairs, umbrellas, and planters) This zone may include existing trees, lampposts, benches, etc. □The number of tables and chairs installed on the public right-of-way depends on the physical configuration of the site and will be determined by the City at the time of issuance of the sidewalk café permit.

PEDESTRIAN - As a public sidewalk, this zone is for the safe and unimpeded passage of pedestrians, wheelchairs, baby carriers, etc. This zone may include existing trees, lampposts, benches and a minimum of 4 foot clear path shall be maintained at all times where these elements exist. All crosswalks must intersect with the Pedestrian Zone maintaining a 4 foot width at all times. At no time shall chairs extend into the Pedestrian Zone.

VEHICULAR - This zone refers to the vehicular travel lane and the on-street parking adjacent to the edge of curb. No improvements are allowed in this zone. Crosswalks are considered within the Vehicular Zone and pedestrian access must extend to the Pedestrian Zone.

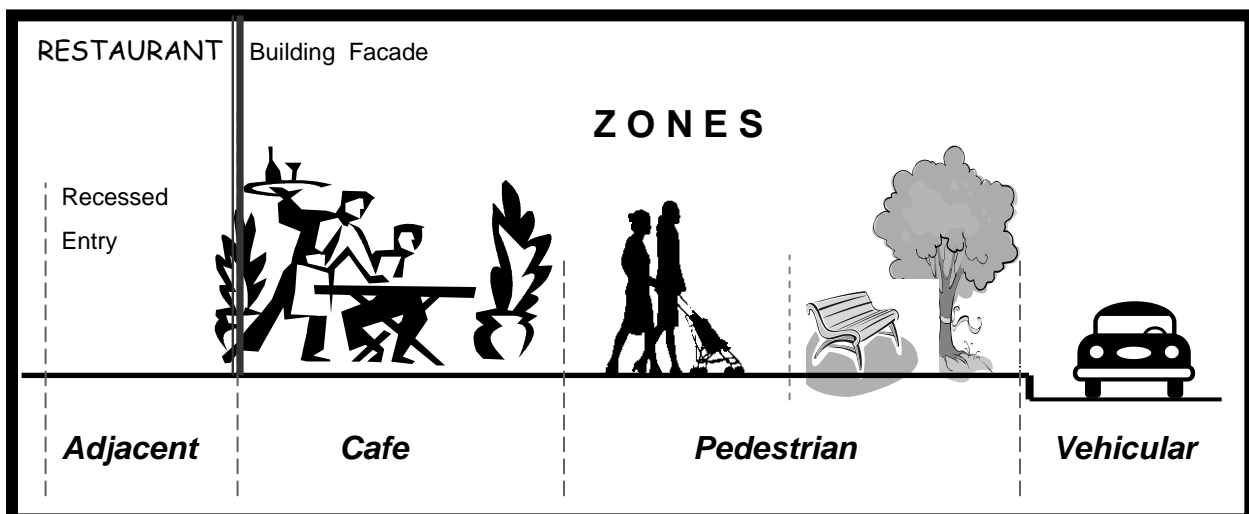

OPERATIONS

HOURS - A business with a sidewalk café may be open for breakfast, lunch and dinner or combination thereof, consistent with the normal hours of operation of the business.

ALCOHOL - Sidewalk cafe permit holder shall be exempt from the restrictions on open containers if such establishment is otherwise licensed to sell alcoholic beverages under the applicable laws and ordinances. The café shall comply with all applicable laws and local ordinances regarding the sale and service of food and beverages to the public, including the Alcohol and Beverage Control requirements for serving alcohol and applicable County Health Regulations. At a minimum, the permit holder must post an 8" x 12" sign with the wording *"No Alcohol Beyond this Point"* at the exit of the café area, designating the limits of the open container area.

**No Alcohol
Beyond
This Point**

LAYOUT

The downtown sidewalk café area contains sidewalk patterns which affect the placement of improvements such as tables and chairs in the public right-of-way. The installation of these improvements is considered temporary in nature. The café area shall be furnished with tables and chairs, and may include umbrellas and planters. The operator shall not make any permanent changes, such as bolting tables to the ground. Improvements shall not be secured to lampposts, streetlights, trees or any other public street furniture. Café improvements shall be removed from the sidewalk and stored inside when required by the City. The sidewalk café improvements may not be stacked or stored outside on the public right-of-way at any time. The sidewalk café must maintain all minimum distances and clearance requirements at all times.

TYPICAL CLEARANCE REQUIREMENTS:

Entrance Door - Five feet clearance from center of doorway at all times

Divider
(bollards & chains)

Must keep four (4) feet minimum clear pedestrian path at all times where street fixtures exist and 8' from face of restaurant building to curb at all streets.

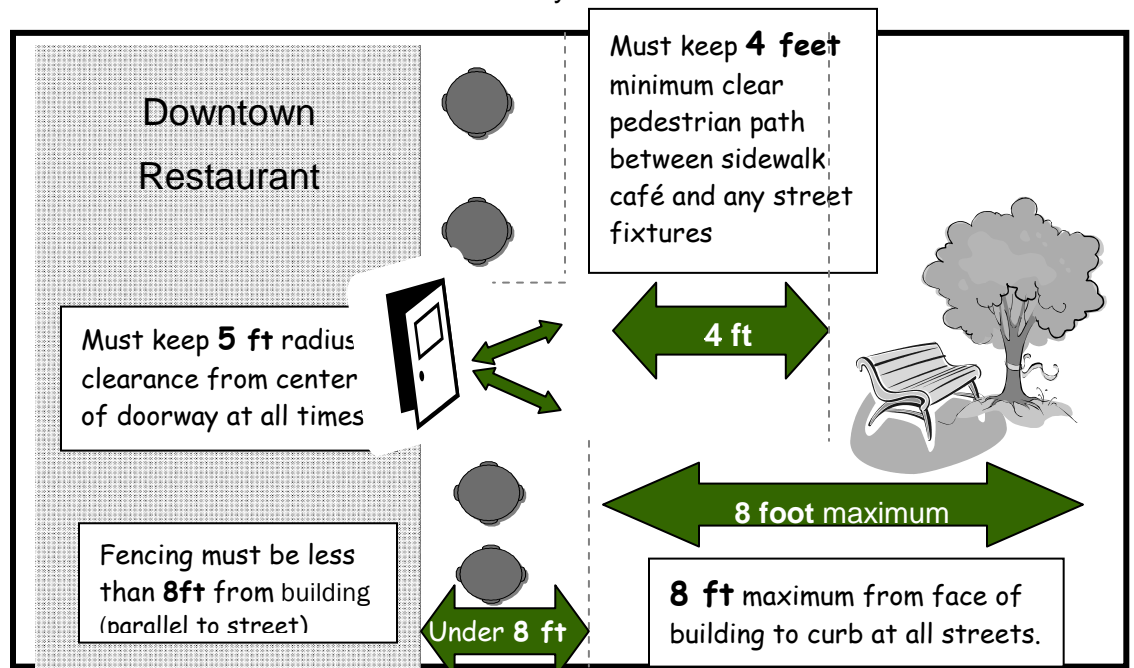

MAINTENANCE

The café operator shall be responsible for the proper maintenance of the café area at all times, including properly disposing of all trash generated by the operation. The café operator shall comply with all State and local regulations related to water disposal.

Pollution Prevention (visit www.cabmphandbooks.com for more information)

Dry cleanup first (sweep, collect, and dispose of debris and trash) when cleaning sidewalk

Regular broom (dry) sweep sidewalk to minimize cleaning

FURNITURE DESIGN

All furnishings must meet the following standards:

TABLES AND SEATING

Round tables shall be no larger than three (3) feet in diameter. Square tables shall be no larger than three (3) feet wide and rectangular tables no more than three (3) x four (4) feet. Tables may be no more than thirty inches (30") in height. Round or square tables shall seat no more than four people, subject to compliance with the clearance requirements. Tables and chairs shall match and be made of safe, sturdy and durable material, such as wood, steel, plastic, and wrought iron. All furniture shall be commercial grade and manufactured for outdoor commercial use. All café furniture shall be properly maintained and cleaned regularly. Stools are not permitted.

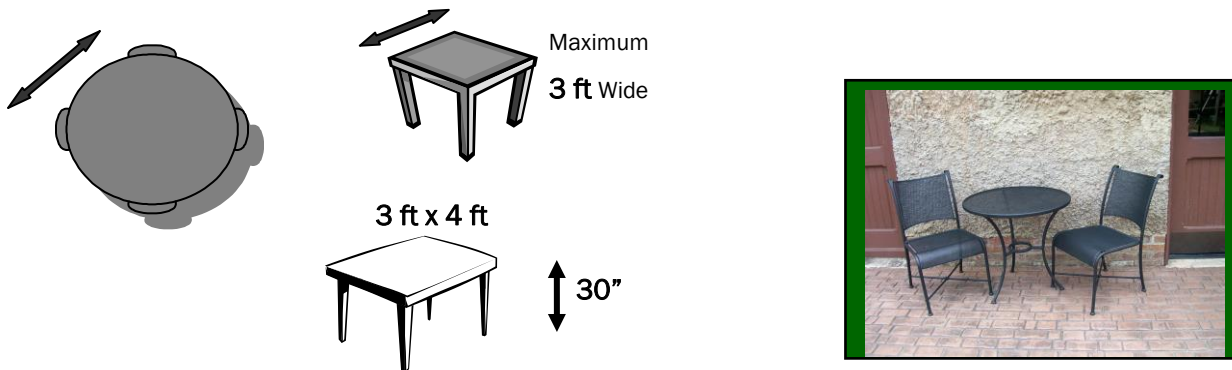

FLOWER BOXES AND PLANTERS

Moveable flower boxes or planters may be used to visually define the corner boundaries and contain the café seating area. To avoid blocking the patron's vision while seated, the combined height of the planters and live plants shall not exceed 4 feet from sidewalk grade. The boxes or planters shall be no greater in height than 2½ ft. and no wider than 2 ft. at the base. The flower boxes and planters shall be portable and be made of safe, durable and attractive material such as wood or steel. All boxes, planters and planting areas must be planted with seasonal blooming or ornamental evergreen live plants year round. The café owner shall be responsible for the prompt removal of all empty or poorly maintained planting areas.

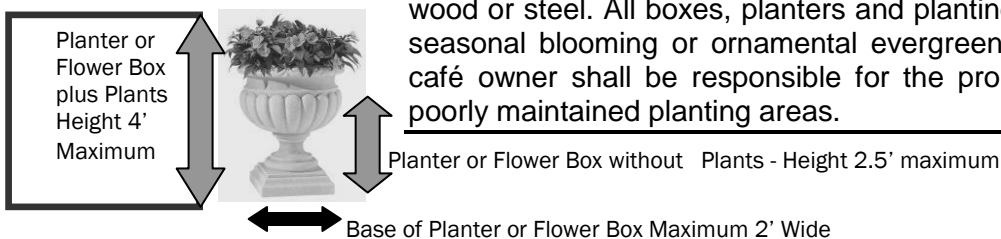

MENU BOARDS & SIGNS

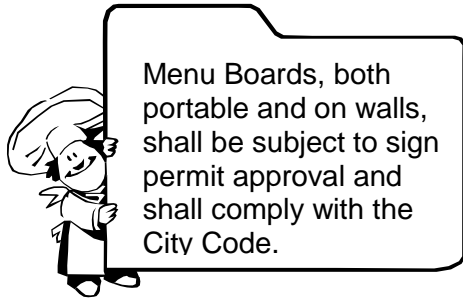

City Code Section 33A, Article 2 and the City Sign Ordinance

For approval contact:

Rome Floyd Planning 706-236-4473

Web site: www.rome.ga.us

UMBRELLAS Individual umbrellas of a compatible design shall not extend over the Pedestrian Zone. Umbrellas shall be made for outdoor commercial use, subject to City approval and may not contain any logo, advertisement or message.

TRASH RECEPTACLES On street receptacles may not be used for disposal of café trash.

TABLE CLOTHES May not be used.

FENCE A system of connected post and railings shall serve to maintain the boundaries of the Sidewalk café where alcohol is served. Flower boxes or planters may be used to define the corner boundaries of the area.



Moveable barriers and fences must be shown on the application site plan and are subject to approval.

APPLICATION REQUIREMENTS

The following items must be submitted to the Downtown Development Department in order to process an application for a Sidewalk Café Permit:

- Application Form
- Site Plan – Scaled and dimensioned
- Site Furniture photograph or cut sheet
- Insurance Requirements - endorsement and certificate
- Indemnification
- Agreement Letter between property owner and business owner

INSURANCE REQUIREMENTS (PLEASE READ CAREFULLY)

ORIGINAL INSURANCE CERTIFICATES NAMING THE CITY OF ROME AS ADDITIONAL INSURED **MUST** BE ATTACHED TO THE APPLICATION BEFORE THE APPLICATION WILL BE PROCESSED. PERMIT HOLDER SHALL SECURE AND MAINTAIN DURING THE PERMIT PERIOD THE FOLLOWING COVERAGES:

COMMERCIAL GENERAL LIABILITY: COMMERCIAL GENERAL LIABILITY IN THE AMOUNT OF \$1,000,000.00 PER OCCURRENCE FOR BODILY INJURY AND PROPERTY DAMAGE. THE CITY OF ROME GOVERNMENT MUST BE NAMED AS AN ADDITIONAL INSURED ON THIS POLICY, AND AN ENDORSEMENT MUST BE ISSUED AS PART OF THE POLICY REFLECTING COMPLIANCE WITH THIS REQUIREMENT. THE CITY OF ROME SHALL BE LISTED AS AN ADDITIONAL INSURED ON THE COMMERCIAL GENERAL LIABILITY.

SITE PLAN SUBMITTAL REQUIREMENTS

A site plan is a dimensioned drawing that shows the general layout of the sidewalk café area and building frontage. The site plan must be drawn to scale and legible and include the following:

1. Measurement of frontage of the building or tenant space serving the proposed sidewalk café
2. Boundaries of the sidewalk café
3. Dimension the distance between the outer boundary of the sidewalk café and the curb. Where there are no permanent or fixed obstructions in the right of way, a minimum of 8'-0" of paved sidewalk must be maintained for sufficient pedestrian traffic
4. Dimension the distance between any permanent or fixed obstructions (sidewalk planters, trees and/or tree grates, light poles, directional or informational signage, trash receptacles) in relation to the boundaries of the sidewalk café area. A minimum distance of 4' 0" is required for pedestrian traffic
5. Number and placement of tables, chairs and any equipment that is to be placed in the sidewalk café area. Must be to scale
6. Plans **MUST** establish that the approved means of egress from the existing building are not blocked, diminished or in any way altered as a result of the new Sidewalk café.

Sample Site Plan

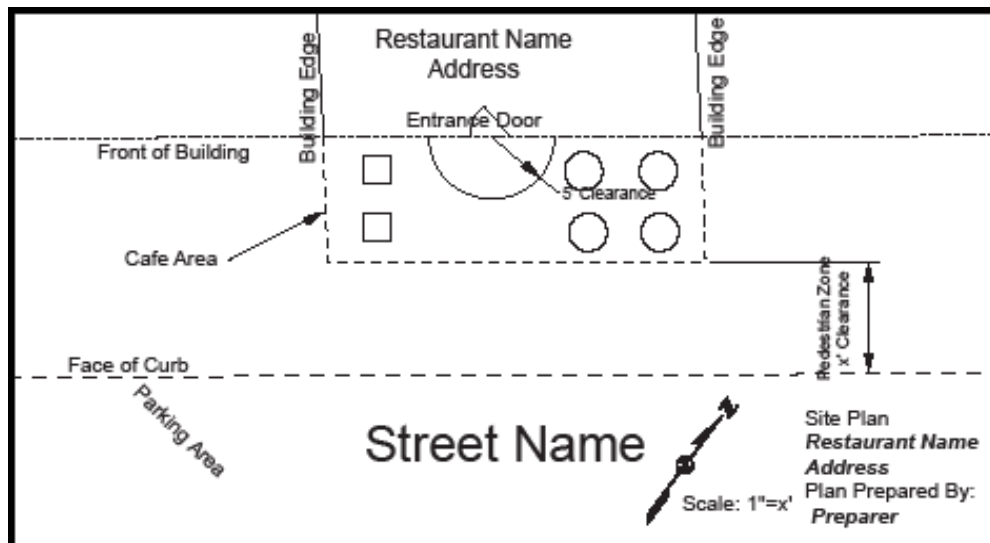



APPLICATION FOR SIDEWALK CAFÉ PERMIT

PERMITS ARE NOT TRANSFERABLE

Application is hereby made for a revocable Sidewalk Cafe permit to operate a Sidewalk café in accordance with CHAPTER 11, Article 11, Section 11-60 of the City of Rome's code of ordinances. **Permits must be renewed annually within the first quarter of each calendar year.**
Incomplete applications will not be processed

Business Name _____ Business Phone _____

Proposed Location _____

Mailing Address (Street City Zip) _____

Name _____ Title _____

Home Address (Street, City, State, Zip) _____

Home Phone: _____ Email _____

Schedule of Days of Operation _____ Hours _____

In specific consideration for the City granting a Sidewalk Café permit to the applicant, the permit holder shall indemnify and hold harmless the City and its respective agents and employees from all suits, actions, claims, demands, damages, losses and other reasonable expenses and costs of every kind and description to which the City, or its agents or employees may be subjected to as a result of the grant of this permit. I hereby state that I have answered all of the preceding questions and that the answers herein and all data, information, documents and evidence herewith submitted is true and correct to the best of my knowledge and belief. I declare under penalty that I am the owner or authorized agent for this property and further acknowledge that I have received and read a copy of the Sidewalk Café Ordinance and Guide.

Signature _____ Date _____

Print Name _____ Any Falsification of answers or material will result in denial.

The following items must be submitted in order to process this application:

- Application Form
- Indemnification
- Copy of Business License
- Insurance Requirement endorsement and certificate
- Agreement Letter between property owner and business owner
- Site Plan - scaled and dimensioned
- Site Furniture photograph or cut sheet
- Copy of Beverage License

OFFICE USE ONLY

DESIGN Approved or Denied Date _____ By _____ File # _____

PERMIT Approved or Denied Date _____ By _____ Permit # _____

Terms or Conditions _____

Inspection Results _____

Inspection Date _____ Inspected By _____

- CHECK LIST
- ___ Insurance Requirement Endorsement & Certificate
 - ___ Indemnification Letter to City
 - ___ Copy of Business License and a copy of Beverage License
 - ___ Agreement Letter between Property and Business Owner
 - ___ Site Furniture photograph or cut sheet
 - ___ Site Plan scaled and dimensioned